

Vacuum Traps and Filters

Adsorption Traps



Single-Stage Vacuum Traps



Multi-Stage Vacuum Traps



Oil Mist Eliminators



Introduction	16-3
Adsorption Traps	
Including Zeolite Filling	16-4
Without Zeolite Filling	16-4
Zeolite	16-4
LN ₂ Cooling Traps	16-5
Single-Stage Vacuum Traps	
VISI-TRAP	16-6
POSI-TRAP	16-7
Multi-Stage Vacuum Traps	
MULTI-TRAP	16-8 to 16-9
Filter Elements	16-10
Oil Mist Separators	
Oil Mist Filters	16-10
High Performance Oil Mist Filters	16-11
Ultra High Performance Oil Mist Filters	16-12

Introduction

VACOM offers a large variety of vacuum traps and oil mist separators. Different solutions come into consideration to fit different individual applications.

KF adsorption traps with heating prevent backstreaming of oil and vapour from the fore-vacuum pipes and mechanical booster pumps into the vacuum chamber. Usually they are filled with zeolite, which catches the gas particles due to its large surface and binds them. The zeolite can be regenerated many times, because of the integrated heater in the adsorption trap.

LN₂ cooling traps of stainless steel are integrated in high vacuum systems to achieve a systematic condensation of process gases or propellants on the cooled surfaces. Water, solvent and oil vapours as well as CO₂ condense at the cooled surfaces at a temperature of 77 K. The cooling traps are equipped with KF or ISO-K flanges for installation into the pump line of the vacuum system and for the outlet of the condensate.

The single- and multi-stage vacuum traps of the American manufacturer MASS-VAC are ideal for protecting pumps and vacuum pipes against contaminations and damages. Numerous variations and sizes are on offer. The traps are equipped with replaceable filter cartridges. Depending on the chosen filter type, diverse particles, condensable gases or other corrosive or reactive materials can be separated.

Oil mist separators bind oil vapour from mechanical boosting pumps and therefore prevent the contamination of the exhaust air. Depending on the pump size, there are different constructions possible. The replaceable filter elements withhold oil particles from a minimum size of 0.1 µm. This corresponds to a separation rate of 99.999 % of the emerging oil vapour.



Adsorption Traps

KF Adsorption Traps, Stainless Steel, Including Heater

Including Zeolite Filling

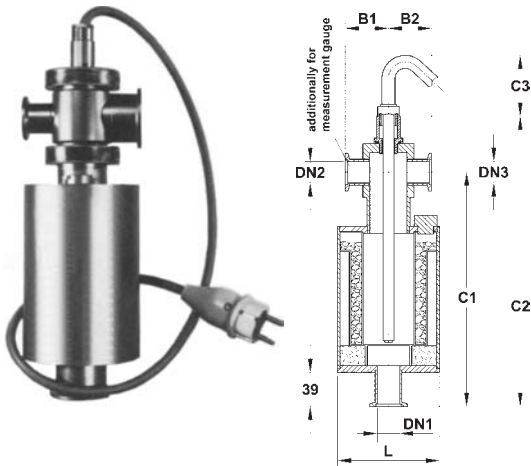

Order code	DN1	DN2	DN3	A	B1	B2	C1	C2	C3
FT25KF-J	25	25	25	104	47.5	47.5	253	285	85
FT40KF-J	40	40	25	104	50	45	253	285	85
FT50KF-J	50	50	25	129.5	50	45	260	300	60

Without Zeolite Filling

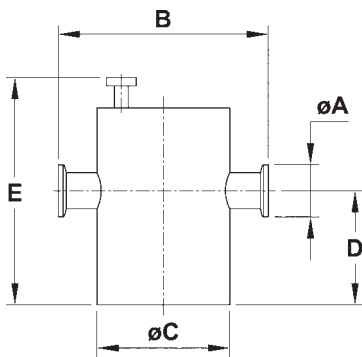

Order code	DN	A	B	C	D	E	Capacity (g)
FT26KF	25	40	230	100	100	170	260
FT52KF	40	55	230	100	200	340	520

Zeolite Filling for Adsorption Traps

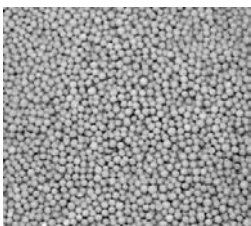

Order code	Mesh size	Quantity (g)
ZEOLITH	10 A	1000

Adsorption Traps

LN₂ Cooling Traps, Stainless Steel

Construction A

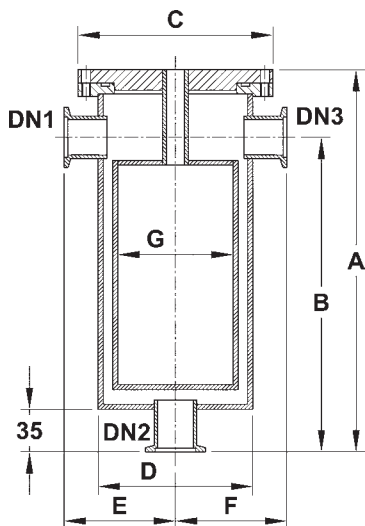

Order code	705101	705102	705104	705105	706106	707107
DN1	DN25KF	DN25KF	DN40KF	DN40KF	DN50KF	DN63ISO
DN2	DN25KF	DN25KF	DN40KF	DN40KF	DN50KF	DN63ISO
DN3	-	DN25KF	-	DN40KF	DN40KF	DN40KF
A	260	260	260	260	265	320
B	220	220	220	220	185	265
C	125	125	125	125	150	150
D	104	104	104	104	129	129
E	75	75	75	75	90	98
F	75	75	75	75	90	98
G	78	78	78	78	101	101

Construction C

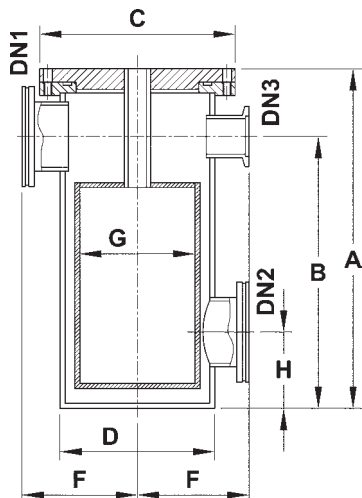

Order code	705111	705112	705114	705115	706116	707117
DN1	DN25KF	DN25KF	DN40KF	DN40KF	DN50KF	DN63ISO
DN2	DN25KF	DN25KF	DN40KF	DN40KF	DN50KF	DN63ISO
DN3	-	DN25KF	-	DN40KF	DN40KF	DN40KF
A	225	225	225	225	230	295
B	180	180	180	180	170	230
C	125	125	125	125	150	150
D	104	104	104	104	129	129
E	75	75	75	75	90	98
F	75	75	75	75	90	98
G	78	78	78	78	101	101
H	35	35	35	35	45	65

Single-Stage Vacuum Traps

VISI-TRAP (Simple Adsorption Trap with Plastic Housing)

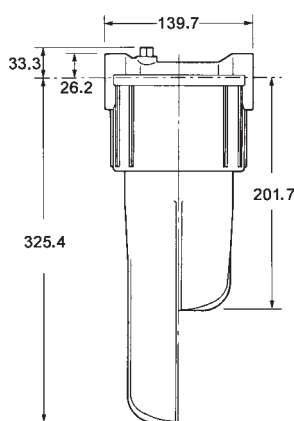

The adsorption trap VISI-TRAP consists of a transparent plastic housing with a particle filter to protect pumps against corrosion or vacuum against the back diffusion of oil from the pump.

Two filter sizes as well as a number of filter cartridges and connection nozzles are available for the individual demands of different applications. Filtering elements against water, oil or corrosive chemicals and fine particles are also available and are replaceable without opening the vacuum system.

Technical data

	MV-300005	MV-300010
Housing material	plastic	plastic
Housing size (mm)	114	241
Pump size (m³/h)	1.5 - 6	9 - 30
Filter	stainless steel end caps and screens, Buna N seals	tainless steel end caps and screens, Buna N seals
Ports	3/4" NPT female thread	3/4" NPT female thread
Adapters	hose connection, DN16KF, DN25KF, DN40KF	hose connection, DN16KF, DN25KF, DN40KF
Diameter (mm)	140	140
Total height (mm)	200	325
Space required for change of housing (mm)	40	40

Order code 4.5" version	Order code 9.5" version	Description
MV-300005	MV-300010	VISI-TRAP with housing, cap and 3/4" NPT female thread (without filter element)
MV-300105	MV-300100	VISI-TRAP with copper gauze
MV-300205	MV-300200	VISI-TRAP with stainless steel gauze
MV-300305	MV-300300	VISI-TRAP with molecular sieve
MV-300405	MV-300400	VISI-TRAP with Sodasorb®
MV-300505	MV-300500	VISI-TRAP with activated charcoal filter
MV-300605	MV-300600	VISI-TRAP with aluminium oxide
MV-300725	MV-300720	replacement housing
MV-301075*	MV-301075*	connecting adapter with hose connection on 3/4" NPT
KF16NPT34*	KF16NPT34*	connecting adapter DN16KF on 3/4" NPT
KF25NPT34*	KF25NPT34*	connecting adapter DN25KF on 3/4" NPT
KF40NPT34*	KF40NPT34*	connecting adapter DN40KF on 3/4" NPT
MV-301200	MV-301200	pressure display (0-30" Hg)
MV-301300	MV-301300	ventilation valve
MV-301400	MV-301400	pressure display and ventilation valve pre-assembled

* Two for each trap.

Please see replacement filters on page 16-10.

Single-Stage Vacuum Traps

POSI-TRAP (Stainless Steel)



POSI-TRAP 4



POSI-TRAP 8

POSI-TRAP filter cartridges are in- and outlet sealed in order to completely filter the inflowing gas. POSI-TRAP housings are available with 180° opening flanges and as 90° versions.

Two POSI-TRAP sizes are available; the 4" type with one filter element and the KF flange DN25 as well as the 8" type with four filter elements and KF flanges DN40 or DN50. Both constructions are equipped with a snap closing, which enables a simple filter element exchange.

Technical data

- Construction stainless steel housing
- Seals Buna N O-rings
- Housing size see drafts

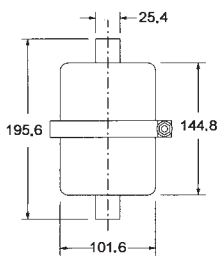

1" tube connection

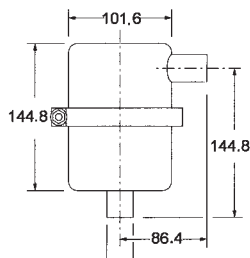

1" tube connection

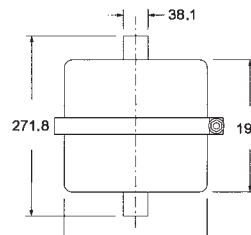

1 1/2" tube connection

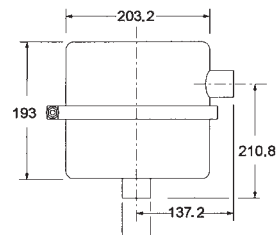

1 1/2" tube connection

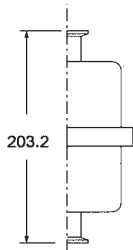

DN25KF

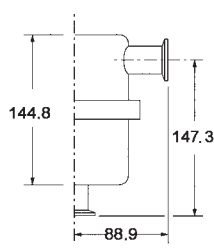

DN25KF

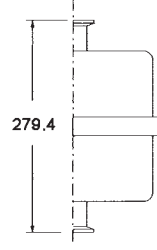

DN40KF/DN50KF

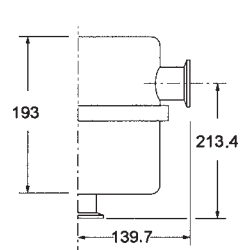

DN40KF/DN50KF

Order code 4" version	Order code 8" version	Description
MV-330000* (1")	MV-340000* (1.5")	POSI-TRAP (180° version) with hose connection
MV-330025*	-	POSI-TRAP (180° version) with KF flanges, DN25KF
-	MV-340040*	POSI-TRAP (180° version) with KF flanges, DN40KF
-	MV-340050*	POSI-TRAP (180° version) with KF flanges, DN50KF
MV-335000* (1")	MV-345000* (1.5")	POSI-TRAP (90° version) with hose connection
MV-335025*	-	POSI-TRAP (90° version) with KF flanges, DN25KF
-	MV-345040*	POSI-TRAP (90° version) with KF flanges, DN40KF
-	MV-345050*	POSI-TRAP (90° version) with KF flanges, DN50KF

* Filter elements are included. Please order by adding the material specific filter code:

KG	copper gauze	SO	Sodasorb®	P2	PolyPro 2 µm
SS	stainless steel gauze	AK	activated charcoal	P5	PolyPro 5 µm
MS	molecular sieve	AA	activated Al ₂ O ₃	P20	PolyPro 20 µm

MULTI-TRAP (Multi-Stage High Performance Vacuum Trap)



The multi-stage high performance vacuum trap MULTI-TRAP protects oil sealed and dry running pumps used within reactive processes (e. g. TEOS, NITRIDE, LTO, HTO, PLASMA). It filters corrosive and during the driving process emitted particles, which would contaminate the vacuum pump, and therefore shortens the downtime or respectively lengthens the maintenance intervals. The three staged configuration offers an almost complete filtering of the flow:

Large and heavy particles as well as aerosols and liquids are filtered during the first stage at the large housing surface. Filter elements in the second and third stage filter reactive chemicals and fine particles. A large number of possible combinations enables a broad range of applications.

The MULTI-TRAP allows easy integration into an existing system. The housing cover can be removed for maintenance or cleaning purposes.

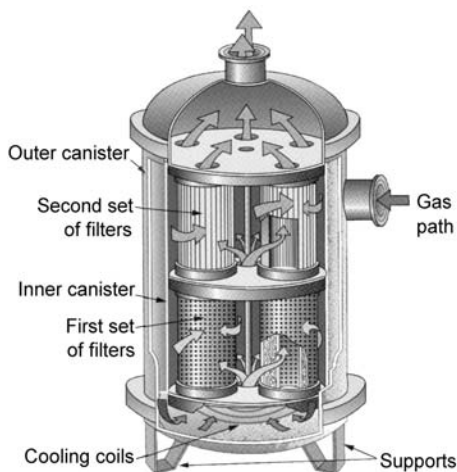

The arrows show the distribution of the process gases.

Constructions

- Five standardised models of different sizes are available
- Each of the MV-355040 and MV-355050 models have two stages with five parallel filter elements.
- Each of the MV-355080 and MV-3550100 models have two stages with six parallel filter elements.
- The model MV-355160 has two stages with eight parallel filter elements.



An additional cooling inductor is available for the models MV-355210 and MV-355212 for higher condensation in the first stage. The inductor is assembled at the bottom of the MULTI-TRAP and can be operated with various cooling systems (water, POLYCOLD). The gas flow has to go through this cooling stage before reaching the second stage with the filter elements.

Multi-Stage Vacuum Traps

MULTI-TRAP (Multi-Stage High Performance Vacuum Trap)

Technical data

	MV-355040	MV-355050	MV-355080	MV-355100	MV-350160
Housing material	stainless steel				
Housing seal	upper and lower housing seal, O-rings of Buna N				
Diameter (mm)	254	254	305	305	406
Total height (mm)	457	457	470	470	622
Mounting flange	DN40KF	DN50KF	DN80ISO-K	DN100ISO-K	DN160ISO-K
External tube diameter (mm)	38.1	50.8	76.2	101.6	152.4

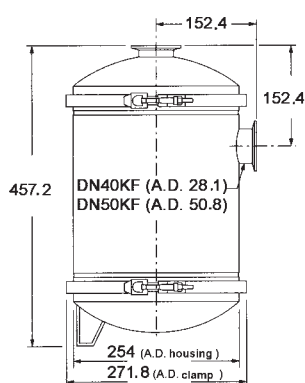

MV-355040 (DN40KF)
MV-355050 (DN50KF)

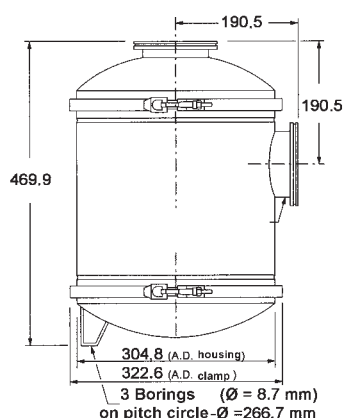

MV-355080 (DN80ISO)
MV-355100 (DN100ISO)

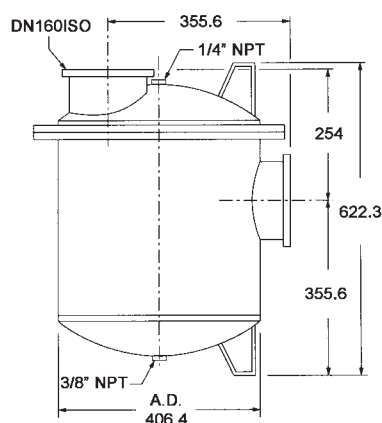

MV-350160 (DN160ISO)

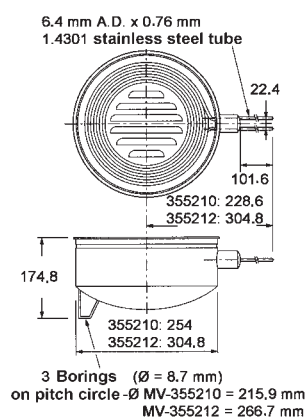

Cold coil for:
MV-355210, MV-355212

Order code	Flange	Description
MV-355040	DN40KF	MULTI-TRAP 10" version; 1.5" in-/output; requires 5 filter elements in stage 2 and 5 elements in stage 3 (not included in the prize)
MV-355050	DN50KF	MULTI-TRAP 10" version; 2" in-/output (filter elements as MV-355040)
MV-355210	-	Option: cooling module for MV-355040 and MV-355050
MV-355080	DN80ISO-K	MULTI-TRAP 12" version; 3" in-/output; requires 6 filter elements in stage 2 and 6 elements in stage 3 (not included in the price)
MV-355100	DN100ISO-K	MULTI-TRAP 12" version; 4" in-/outlet (filter elements as MV-355040)
MV-355212	-	Option: cooling module for MV-355080 and 355100
MV-350160	DN160ISO-K	MULTI-TRAP 16" version; 6" in-/outlet; requires 8 filter elements in stage 2 and 8 elements in stage 3 (not included in the price)

Multi-Stage Vacuum Traps

Filter Elements (Cartridges for all Traps)



The filter elements are equipped with stainless steel end caps and Buna N seal rings for a long lifetime and durability. The large selection of filter elements and possible combinations enables a wide range of applications. Additionally it is also possible to deliver customised filter elements as required.

The filter elements are exchangeable and available in two sizes as well as of the following materials:

Order code 4.5" version	Order code 9.5" version	Material	Application
MV-300905	MV-300900	copper gauze	large surface absorbs condensate, particles and oil vapour
MV-300915	MV-300910	stainless steel gauze	such as copper gauze, only with corrosion protection
MV-300925	MV-300920	molecular sieve	reduces backstreaming of oil and vapour
MV-300935	MV-300930	Sodasorb®	filters corrosion particles, chemicals and neutralises acid vapours
MV-300945	MV-300940	activated charcoal filter	filters organic vapours
MV-400915	MV-400910	activated aluminium	filters acids, polar compounds, water and particles
MV-400925	MV-400920	PolyPro 2 µm	filters particles up to Ø 2 µm
MV-400935	MV-400930	PolyPro 5 µm	filters particles up to Ø 5 µm
MV-400945	MV-400940	PolyPro 20 µm	filters particles up to Ø 20 µm

Oil Mist Separator

OME (Oil Mist Eliminator with Transparent Housing)



Oil mist separators are assembled on the exhaust of rotary vane pumps to minimise the impact on the environment by filtering the oil mist emitted from the pump.

The OME oil mist eliminator is equipped with filter elements with a low gas resistance and filters oil mist of 0.1 µm at 99.999 %. Due to the transparent housing, it is possible to control the liquid stage of the separated oil.

Technical data

- Transparent polypropylene housing
- Buna N seal rings
- Replaceable filters of synthetic resin with imbedded glass fibres
- Separation percentage for oil mist: 99.999 %
- All-round mountable, bend and other adapters available
- Connections 3/4" NPT female thread
- Options adapter up to 1.0" (25 mm) for hose connection or DN25KF available
- Dimensions see figure
- Weight 1.1 kg

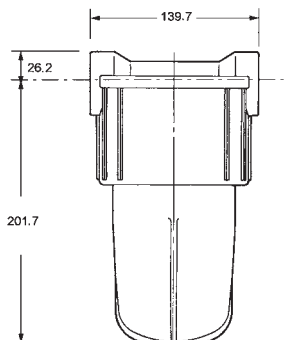

Order code	Description
MV-360500	OME oil mist eliminator with transparent housing, with one filter element
KF25NPT34	KF adapter, DN25
MV-301075	3/4" hose connection
MV-360905	replacement filter element

HCOME (High Capacity Oil Mist Eliminator)



HCOME 4

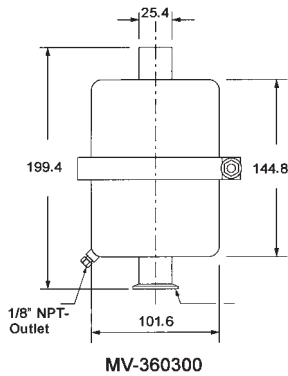

MV-360300



HCOME 8

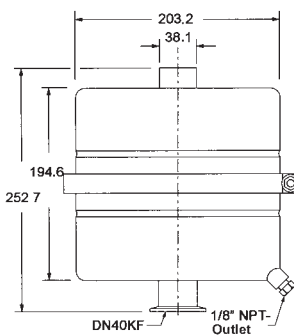

MV-360200

The high performance oil mist separator HCOME is generally used for pumps with a pumping speed higher than 25 m³/h. Replaceable filters of synthetic resin with imbedded glass fibres enable a bonding of the oil mist at the pumps exhaust. Further fields of application are corrosive processes or applications using acetone as well as limited space requirements, where the oil mist filter has to be mounted directly on the pump exhaust. Furthermore the HCOME has an oil outlet unit for the oil feedback and can easily be disassembled and cleaned for maintenance purposes.

The HCOME 4 (HCOME 8) consists of one (three) filter element(s) and can be used for pumps with a direct fitting up to DN40KF (DN50KF). In general, the HCOME connection should not be smaller than 1.5 times the size of the pumps inlet port.

Technical Data

- Stainless steel housing
- Replaceable filters of synthetic resin with imbedded glass fibres
- Connections for 4" version KF flange, DN25 on pump side, 1" hose connection for exhaust
- Connections for 8" version KF flange, DN40 on pump side, 1 1/2" hose connection for exhaust

Dimensions	4" Version	8" Version
Diameter (mm)	102	203
Total height (mm)	199	252
Weight (kg)	1.4	4.5

Order code 4" version	Order code 8" version	Description
MV-360300	MV-360200	HCOME (high performance oil mist filters), number of filter elements: MV-360300 = 1, MV-360200 = 3
KF25NPT34	KF40NPT34	KF flange adapter (DN25 or DN40 on NPT3/4" thread)
MV-301110	MV-301115	exhaust adapter on KF flange DN25 or DN40 (Please indicate the manufacturer/type of the pump.)
KF25C	KF40C	KF clamp ring, DN25 or DN40
KF25SVCR	KF40SVCR	KF centring ring, DN25 or DN40, stainless steel/FKM
EL25K	EL40K	KF bend 90°, DN25 or DN40, stainless steel
KF25VR	KF40VR	replacement O-rings
MV-360915	MV-360915	replacement filter elements

Maxi-HCOME (High Capacity Oil Mist Eliminator)



The ultra high performance oil mist separator MAXI-HCOME consists of five parallel filter elements and can be used for pumps with a maximal pumping speed of 300 m³/h. There is also the possibility of oil feedback through an outlet unit.

Technical Data

■ Housing material	stainless steel
■ Connections	DN50KF on pump side, 1.5" NPT thread on exhaust side
■ Filters	five parallel, replaceable filters of synthetic resin with imbedded glass fibres (pore size 0.1 μ)
■ Diameter	254 mm
■ Total height	343 mm
■ Weight	6.8 kg

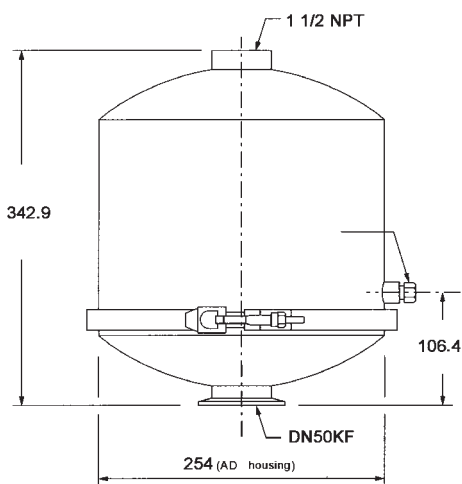

Order code	Description
MV-360000	incl. 5 filters and drain valve
KF50C	accessories: KF clamp rings, DN50
KF50SVCR	accessories: KF centring ring, stainless steel/FKM, DN50
EL50K	accessories: KF bend, 90°, DN50
MV-360915	replacement filter element
KF50VR	replacement O-ring, DN50
MV-371018	replacement drain valve