

# Ion Getter and Titanium Sublimation Pumps

Ion Getter Pumps (IGP)



IGP Controllers



Titanium Sublimation Pumps (TSP)



TSP Controllers



## Ion Getter Pumps

Introduction - UHV Pump Technology	Page 13-3
Overview of ion getter pumps	Page 13-4 to 13-5

## Ion Getter Pump Controllers

Introduction	Page 13-6
DIGITEL™ high voltage power supplies for IGP	Page 13-7 to 13-10

## Titan Sublimation Pumps

Introduction - combination Pumps TSP - IGP	Page 13-11
Titanium sublimation pumps	Page 13-11
Ambient sputter shield	Page 13-11
LN <sub>2</sub> cryo shroud	Page 13-12

## Titanium Sublimation Pump Controllers

DIGITEL™ MPC TSP/NEG power supply	Page 13-13
SUBLI-CON51	Page 13-13

## Basic Technical Principles

General information about IGP	Page 13-14
Characteristics of IGP	Page 13-14
Pumping mechanism of diode ion pumps	Page 13-15
Pump element styles	Page 13-16

## Introduction - UHV Pump Technology

Special vacuum pumps are usually necessary in the ultra high vacuum technology in order to fulfil its demanding requirements. Especially ion getter pumps (IGP) and titanium sublimation pumps (TSP) are used. VACOM is the official distributor of Gamma Vacuum, a leading manufacturer of IGP, TSP and controllers.

This chapter gives an overview of the Gamma Vacuum product range and further products of the UHV pump technology. Further information about Gamma Vacuum products can be obtained from the webpage [www.gammavacuum.com](http://www.gammavacuum.com) or from the Gamma Vacuum catalogue, which we will be pleased to send you on request.

## TiTan™ Ion Getter Pumps

To achieve final pressures between  $10^{-9}$  mbar and  $10^{-12}$  mbar in UHV applications, it is necessary to select your technical equipment for your UHV systems carefully. Ion getter pumps were developed especially for the requirements in the UHV regime and basically do not need any maintenance due to the absence of moving parts.

Ion Getter Pumps of the TiTan™ series from Gamma Vacuum have diode pump elements and meet all requirements of UHV applications with respect to pumping speed, stability and lifetime. Pumping elements and housing sizes can be tuned to match the requirements of the planned application. You can choose between three pump categories (small, low, tall profile) and three pump element types (conventional TiTan™ CV, noble gas stable differential TiTan™ DI and noble gas stable TiTan™ 30). The essential criteria for the appropriate configuration of an ion getter pump are the pumping speed, noble gas stability and housing size.

### Pumping speed

The pumping speed of an ion getter pump is determined mostly by the material of the metal cathode. Plates of titanium are used in conventional pump elements, because the element quickly forms chemical compounds with most gases in the air. A new titanium surface has a pumping speed of about 0.6 l/s per  $\text{cm}^2$ . Nitrogen for instance forms titanium nitride, which is a non-reactive solid. Noble gases do not react with titanium, but it is possible to implant these atoms several atomic layers deep into the solid body of the cathode. But it could possibly happen that the noble gases are released, which leads to a temporary increased pressure. The occurrence of noble gases has to be taken into consideration in order to select the appropriate pump element.

### Noble gas stability

Noble gas stability is achieved by using tantalum as cathode material. Tantalum has a far higher density than titanium. Noble gas ions are not implanted into the tantalum cathode plate. They are reflected as high energy neutrals instead. These neutral particles accumulate in areas of the pump, which are not exposed to the continuing ion bombardment, but are a preferred location for accumulating sprayed material. In comparison to titanium, fewer noble gases are released if tantalum is used.

### Housing sizes

The housing size of an ion getter pump is determined by the size, type and number of the pump elements. There exists a selection of TiTan™ ion getter pumps including up to 16 pump elements. The more elements are used, the higher the pumping speed but also the housing. One single element can have, depending on its type, a pumping speed of up to 50 l/s.

## TiTan™ pump elements

TiTan™ pump elements from Gamma Vacuum are diode pump elements. 3 different types are available providing an optimum pump efficiency for your application.



### TiTan™ CV

The original ion pump element with two pure titanium cathodes for the highest pumping speed in HV and UHV and stability for all reactive gases as well as nitrogen.



### TiTan™ DI

Noble gas stable pump element with one titanium and one tantalum cathode; high pumping speed in HV and UHV for noble gases; high-performance for all other gases.

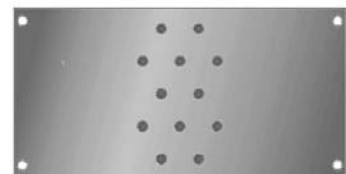

### TiTan™ 30

Pump element with 2 titanium cathodes with cell centres composed of 30 % tantalum; higher noble gas stability in UHV; applicable against minor air leaks and noble gas loads in the range  $< 10^{-7}$  mbar.

## Selecting a TiTan™ Ion Getter Pump

### Housing Sizes\*

#### Technical data

■ Lifetime	average 50,000 h at $10^{-6}$ mbar
■ Final pressure	$<10^{-11}$ mbar
■ Housing material	stainless steel 304
■ Bakeout temperature	250 °C max. (95 °C small pump 3) with magnets 450 °C without magnets
■ Starting pressure	$<10^{-4}$ mbar

### Small ion pumps with small pumping speed (max. 75 l/s)



Mini



3S



10S



25S



45S



75S

	Mini	3S	10S	25S	45S	75S
<b>Pumping speed (l/s)</b>	2 - 3	2 - 3	8 - 10	15 - 20	30 - 40	40 - 75
<b>Dimensions (mm)</b>	38 x 38 x 51	45 x 45 x 108	107 x 113 x 190	202 x 125 x 130	209 x 251 x 130	277 x 242 x 130
<b>Weight (kg)</b>	0,35	0,35	6	9	16	20
<b>Flange</b>	DN16CF-R	DN16CF-R	DN40CF-R	DN40CF-R	DN40CF-R/ DN63CF-R	DN40CF-R/DN63CF-R DN100CF-R

### Medium-size and large low profile (max. 600 l/s)



100L



200L



300L



400L



600L

	100L	200L	300L	400L	600L
<b>Pumping speed (l/s)</b>	80 - 100	160 - 200	240 - 300	320 - 400	480 - 600
<b>Dimension (mm)</b>	325 x 325 x 128	325 x 413 x 233	325 x 413 x 337	325 x 413 x 413	325 x 513 x 513
<b>Weight (kg)</b>	29	49	66	72	103
<b>Flange</b>	DN100CF	DN160CF	DN160CF	DN160CF	DN160CF

\* The illustrations are not true to scale.

For more detailed information please send us a request for the Gamma Vacuum catalogue.

## Selecting a TiTan™ Ion Getter Pump

### Medium-sized and large low profile ion pumps (max. 800 l/s)



400LX



600LX



800LX

	400LX	600LX	800LX
<b>Pumping speed (l/s)</b>	320 - 400	480 - 600	640 - 800
<b>Dimensions (mm)</b>	508 x 413 x 233	508 x 413 x 336	508 x 413 x 413
<b>Weight (kg)</b>	115	115	124
<b>Flange</b>	DN160CF	DN160CF	DN160CF

### Medium-size and large tall profile ion pumps (max. 600 l/s)



150TV



300TV



600TV

	150TV	300TV	600TV
<b>Pumping speed (l/s)</b>	120 - 150	240 - 300	400 - 500
<b>Dimensions (mm)</b>	338 x 247 x 231	345 x 450 x 231	525 x 450 x 305
<b>Weight (kg)</b>	32	65	109
<b>Flange</b>	DN100CF	DN160CF	DN160CF

### DIGITEL™ High Voltage Power Supplies for Ion Getter Pumps



DIGITEL™ SPC  
HV power supply for pumps to 75 l/s



DIGITEL™ LPC  
HV power supply for pumps to 300 l/s



DIGITEL™ MPCe  
HV power supply for pumps from 100 l/s

In order to operate ion getter pumps (IGP) a high voltage supply of 3 - 7 kV is required. High voltage power supplies of the DIGITEL™ series from Gamma Vacuum are designed to operate IGPs of all kinds. The DIGITEL™ series is based on decade-long experience in developing and manufacturing high voltage power supplies for IGP. Besides up-to-date microelectronics for control and inspection, other long proved components for the high voltage generation are used. We deliver three different types: DIGITEL™ SPC for small pumps, DIGITEL™ LPCe for small and medium-size pumps and the universal usable DIGITEL™ MPCe.

#### Output Power

Ion getter pumps are exposed to different conditions during the start and operation time. No matter whether the starting process occurs in the high pressure range, sudden pressure changes or continuous operation in the UHV, the power supply for an IGP always has to provide the right operational current. This can range from only a few  $\mu\text{A}$  up to several 100 mA. DIGITEL™ high voltage power supplies provide the necessary capacities and monitor the system at the same time, even if only a fraction of the maximal power is needed. The DIGITEL™ series provides outputs of 20 W, 200 W and 1000 W per power supply.

#### Functionality

Ion getter pumps require very low power in the ultra high vacuum. The DIGITEL™ high voltage power supplies frequently measure these power inputs and react towards changes within milliseconds. This reaction could be a result of an increased power, an immediate cut-off to prevent damages, the setting of setpoints or the sending of data via the serial interface. During the operation time the pressure is frequently determined. Pressure, pumping current or high voltage can be read also from a distance, because of the large displays. In addition pumping current and high voltage can also be read out via analogue outputs.

#### Safety

Using high voltages requires special precautions. Every single DIGITEL™ HV power supply is equipped with SAFECONN™, a security interlock system. It prevents that wires carrying high voltages are unprotected. Besides the protection of the user, it is also necessary to offer a sufficient protection for the pump and the power supply. The controlling software AutoStart and the AutoRun supply the connected pumps automatically with the correct power that is matched to the pump size.

#### SAFECONN™ Security Interlock

The SAFECONN™ security interlock protects the user from electrical shocks. If the pump is operated with the SAFECONN™ cable and the DIGITEL™ HV power supply, the high voltage will be switched-off, as soon as the cable connection between pump and power supply is disconnected. Here, it doesn't matter whether the connection is disconnected at the pump or the power supply. Switching-on the high voltage will be impossible as well.

#### AutoStart

This feature determines the optimal start and operating conditions for the connected pump. It starts the pump and monitors the starting process independently without intervention of the operator. Because ion getter pumps have a high power consumption during the starting processes, DIGITEL™ high voltage power supplies work in a "protected" starting mode, at which power consumption, voltage, power requirement and the time are monitored. After the pump is started correctly, the power supply switches to continuous operation.

If the start fails, the power supply will switch itself into "cooling mode" for the protection of the pump and the power supply. The starting attempt will be repeated several times after a certain time and will always be stopped in case of failure.

#### AutoRun

After starting the pump, the DIGITEL™ high voltage power supplies switch to continuous operation, during which the ion getter pump has only low power requirements. In case of sudden high operating currents, flashovers will be prevented via special circuits. If the pump does not start operating normally again, the power supply will switch into "cooling mode".

#### Serial Interface RS232/422/485

Via serial interfaces DIGITEL™ high voltage power supplies can be operated by PC or SPS. All commands can be transmitted and the operating data can be read out. In addition to that, an update of the operating software is possible as well.

## DIGITEL™ High Voltage Power Supplies for Ion Getter Pumps

### DIGITEL™ SPC

The DIGITEL™ SPC is useful for the complete operation of small IGP or for maintaining already evacuated IGP in the lower pressure range. The device can either operate with the provided power supply or with batteries.

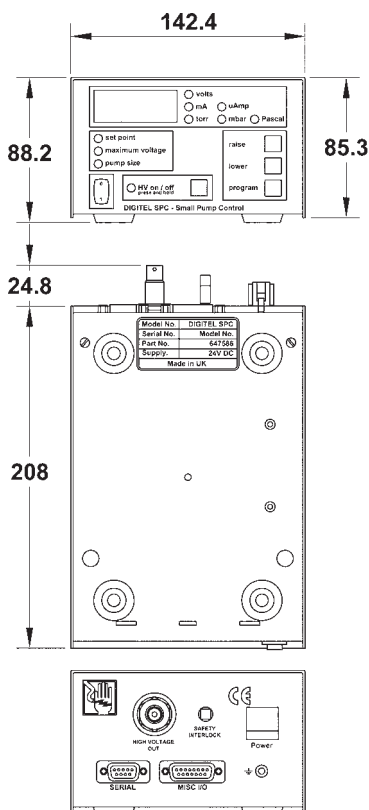

#### Technical data

- Dimensions 140 x 90 x 250 mm
- Operating voltage 24 V DC, with power supply 100 to 240 V AC (50/60 Hz)
- Output power
  - high voltage  $\pm 3500 - 7000$  V DC programmable
  - short circuit current 20 mA
  - max. output 20 W
  - resolution 0.1 nA
- High voltage connection 10 kV Kings SHV
- Display
  - type multi-segment LED
  - readouts pressure (pascal, mbar, torr), current, voltage, programmable options
- Analogue outputs
  - voltage 1 V per 1 kV, user configurable
  - current 1 V per 1 mA, user configurable
- Set point 1 relay, contacts on/off
- Operational conditions
  - environmental humidity 0 to 80 %, non-condensing
  - operating temperature 0 to 40 °C
- Serial interfaces RS232, RS422, RS485
- Conformity standards EN 55011 Class A, IEC 801-2, IEC 801-3, IEC 801-4, EN 61010-1
- Weight 1.5 kg

Order Code	Description
<b>S1PEC23232NN</b>	DIGITEL™ SPC, pos. HV, incl. power supply
<b>S1NEC23232NN</b>	DIGITEL™ SPC, neg. HV, incl. power supply

## DIGITEL™ High Voltage Power Supplies for Ion Getter Pumps

### DIGITEL™ LPC

The DIGITEL™ is qualified for the use with pumps with a minimal pumping speed of 8 l/s. It is possible to connect a maximum of 2 pumps to the HV power supply. A large LCD touch screen indicates all relevant data.

#### High voltage power supply

The device is equipped with a high voltage transformer. A HV output is standard. Up to two HV outputs are possible if needed. The transformer has a power of 200 W (100 mA). The device is delivered with either 7 kV or 5.6 kV.

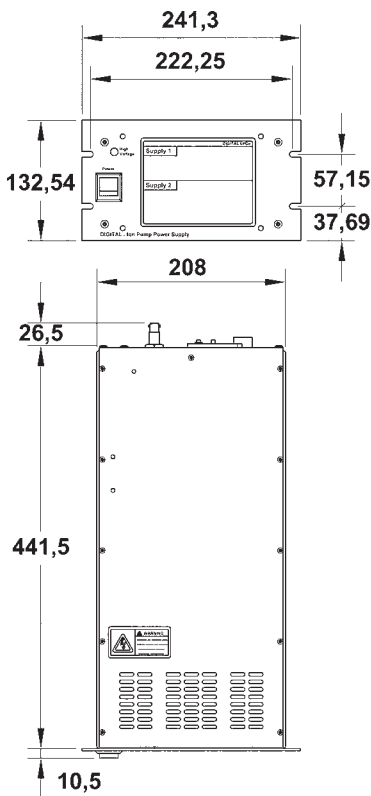

#### Technical data

- Dimensions 241 x 133 x 476 mm
- Operating voltage 120, 220 or 230 V AC (configurable), 48 - 62 Hz
- Output
  - transformer power supply 1
  - high voltage  $\pm 5600$  or  $\pm 7000$  (without current flow)
  - short circuit current 100 mA
  - max. output 200 W
  - resolution 0.1  $\mu$ A
- High voltage connection 1 - 2, 10 kV Kings SHV or Fischer
- Display
  - type  $\frac{1}{4}$  VGA LCD with touch screen function
  - indicated data pressure (pascal, mbar, torr), current, voltage or specific input data (selective)
- Analogue outputs
  - voltage 1 V pro 1 kV, user configurable
  - current 0 - 10 V, logarithmic, user configurable
- Set points 4 TTL, 4 relays
- Operational conditions
  - environmental humidity 0 to 80 %, non-condensing
  - operating temperature 0 to 40 °C
- Serial interfaces RS232, RS422, RS485
- Further equipment AutoStart/AutoRun, SAFECONN, HV on/off remote control
- Conformity standards EN 55011 Class A, IEC 801-2, IEC 801-3, IEC 801-4, EN 61010-1
- Weight 16.8 kg

Order code	Description
L12323NN1P7K1	DIGITEL™ LPC, +7 kV, 230 V AC, 1 x 10 kV SHV output
L12323NN1N7K1	DIGITEL™ LPC, -7 kV, 230 V AC, 1 x 10 kV SHV output

Further configuration possibilities on request.

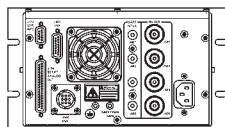

## DIGITEL™ High Voltage Power Supplies for Ion Getter Pumps

### DIGITEL™ MPCe

The DIGITEL™ MPCe is configurable and universally applicable to pumps with a minimum pumping speed of 8 l/s. It is possible to connect up to 2 HV power supplies with up to 4 pumps. A large LCD touch screen shows all relevant data.

### High voltage power supply

The device can be equipped with one or two high voltage transformers. One HV output per transformer is standard. Up to four HV outputs are optionally possible. Two transformer dimensions are offered: 200 W (100 mA) for pumps with a min. 8 l/s and 1000 W (500 mA) for pumps with min. 80 l/s pumping speed. Alternatively the device can be delivered with 7 kV or 5.6 kV.

### Control of a titanium sublimation or NEG pump

Together with the TSP/NEG current supply, available as option, the control of a TSP or NEG pump is possible with the help of the DIGITEL™ MPCe HV power supply. The control switches the TSP/NEG current supply cyclically depending on time and pressure and monitors current and power requirements of the connected TSP or NEG.

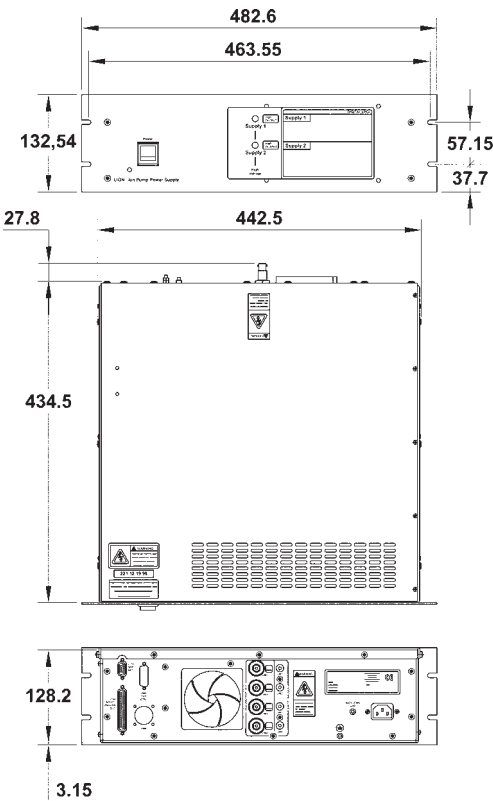

### Technical data

- Dimensions 483 x 133 x 476 mm
- Operating voltage 120, 220 or 230 V AC (configurable), 48 - 62 Hz
- Output
  - transformer power supply 1 or 2
  - high voltage, power supply #1 ±5600 or ±7000 V DC (without current flow)
  - high voltage, power supply #2 ±5600 or ±7000 (without current flow)
  - short circuit current, power supply #1 100 mA or 500 mA
  - high voltage, power supply #2 100 mA or 500 mA
  - max. output 200 W or 1000 W each
  - resolution 0.1 µA
- High voltage power supply 1 - 4, 10 kV Kings SHV or Fischer
- Display ¼ VGA LCD with touch screen
- Readouts pressure (pascal, mbar, torr), current, voltage or specific input data (selective)
- Analogue outputs
  - voltage 1 V pro 1 kV, user configurable
  - current 0 - 10 V, logarithmic, user config.
- Set points 4 TTL, 4 relays
- Operational conditions
  - environmental humidity 0 to 80 %, non-condensing
  - operating temperature 0 to 40 °C
- Serial interfaces RS232, RS422, RS485
- Further equipment
  - optional AutoStart/AutoRun, SAFECOMM, TSP remote control, HV on/off remote control
- Conformity standards EN 55011 Class A, IEC 801-2, IEC 801-3, IEC 801-4, EN 1010-1
- Weight 16.8 kg min., 25.4 kg max.

Order code	Description
M12323NN5P7K1NNNN	DIGITEL™ MPC, 1 x HV power supply (500 mA / +7 kV), 230 V AC, 1 x 10 kV SHV output
M22323NN1P7K11P7K1	DIGITEL™ MPC, 2 x HV power supply (100 mA / +7 kV), 230 V AC, 2 x 10 kV SHV output
M22323NN5P7K15P7K1	DIGITEL™ MPC, 2 x HV power supply (500 mA / +7 kV), 230 V AC, 2 x 10 kV SHV output

Further configuration possibilities on request.

## DIGITEL™ High Voltage Power Supplies for Ion Getter Pumps

### SAFECONN™ high voltage cable

The handling of electrical high voltage requires high safety measures to avoid accidents. The power supplies and high voltage feedthroughs of our ion getter pumps are serially equipped with 10 kV SHV connectors as high-voltage power supply from size TiTan10S and are connected with the SAFECONN™ high voltage cable.

There are contacts on the SAFECONN™ pump side end of the high voltage cable, which enable a separate ground connection between power supply unit and pump housing. As soon as a high voltage cable is not properly connected, the DIGITEL™ power supply units disconnect the power supply to the pump.

The SAFECONN™ also avoids that the power supply unit shows a pressure value by mistake although the cable is not attached. Normally it can happen that a power supply unit detects a low current. This signal could be misinterpreted by the high voltage power supply and could cause a pressure reading. The SAFECONN™ avoids that and an error message will be displayed.

SAFECONN™ high voltage cables are screened and have an insulation of silicone rubber. They are high temperature stable, radiation resistant, very flexible and durable. The connector inserts consist of PEEK, a temperature and radiation resistant plastic material.

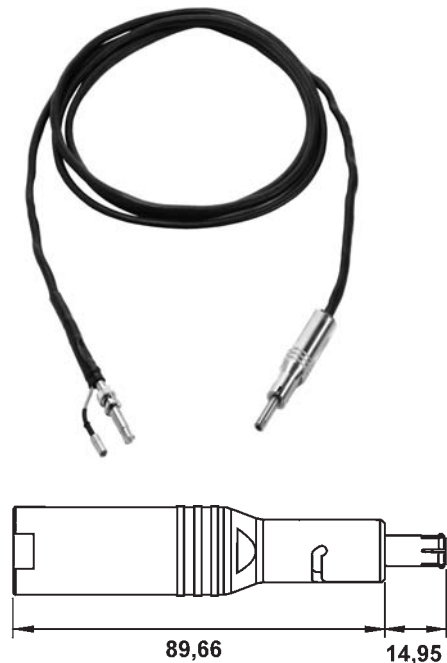

Metals/alloys	Radiation resistance (Grey)*
Beryllium/copper	>10 <sup>8</sup>
Brass	>10 <sup>8</sup>
Bronze/Tin	>10 <sup>8</sup>
Copper/Tin	>10 <sup>8</sup>
ELGILOY (ASTM F 1058)	>10 <sup>8</sup>
Phosphor bronze	>10 <sup>8</sup>
Silver solder	>10 <sup>8</sup>
Stainless steel	>10 <sup>8</sup>

Nonmetal	Radiation resistance (Grey)**
Fiber glass	2 x 10 <sup>7</sup>
Nylon (polyimide)	5 x 10 <sup>7</sup>
PolyEtherEtherKeton (PEEK)	5 x 10 <sup>7</sup>
PolyEthylene (PE)	1 x 10 <sup>6</sup>
PolyOlefin (PO)	1 x 10 <sup>6</sup>
PolyVinylChloride (PVC)	2 x 10 <sup>6</sup>
Silicone rubber	2 x 10 <sup>5</sup>
FPM	2 x 10 <sup>5</sup>

\* (Source: P. Beynel, P. Maier and H. Schonbacher, Compilation of Radiation Damage Test Data, Part III: Materials Used Around High-Energy Accelerators, Copyright by CERN, 1982.)

\*\* (Source: E. Avallone and T. Baumeister, Mark's Standard Handbook for Mechanical Engineers, Copyright by McGraw-Hill Companies, Inc., 1996)

Order code	Description
SCP-SC3-SC	SAFECONN™ cable, 3 m
SCP-SC6-SC	SAFECONN™ cable, 6 m
SCP-SC10-SC	SAFECONN™ cable, 10 m
SCP-SC30-SC	SAFECONN™ cable, 30 m

Other lengths on request.

## Titanium Sublimation Pumps (TSP)

Titanium Sublimation Pumps (TSP) are often used in combination with ion getter pumps, because they have an especially high pumping speed for some gases. In a TSP, filaments of a titanium alloy are heated electrically until titanium sublimates from the surface of the filaments into the vacuum. The titanium sublimates to the nearby areas and forms a thin layer. This layer has a high pumping speed for reactive gases, which either form a chemical compound or are adsorbed. But with increasing covering by these gases the pumping speed decreases. By cooling the surfaces with water or liquid nitrogen it is possible to increase the pumping speed considerably. TSP are especially useful for gases such as H<sub>2</sub>O, CO, CO<sub>2</sub> and O<sub>2</sub>. Using nitrogen cooling, H<sub>2</sub> and N<sub>2</sub> can be effectively pumped as well.

Gas type	H <sub>2</sub>	D <sub>2</sub>	H <sub>2</sub> O	CO	N <sub>2</sub>	O <sub>2</sub>	CO <sub>2</sub>
300 K	2.6	3.1	7.3	8.2	3.5	8.7	4.7
77 K	17	6.2	14.6	11	8.2	11	9.3

Maximal pumping speed in l/s cm<sup>-2</sup> of Ti films at different temperatures.  
(Source: Kimo M. Welch, Capture Pumping Technology, Pergamon Press, 1991)

### Combination Pumps TSP-IGP

For the combination of TSP and IGP, the IGP is equipped with a second mounting flange of the size DN160CF. A non-cooled ambient sputter shield or a LN<sub>2</sub> liquid cryo shroud are attached to that flange. The ambient sputter shield and the cryo shroud provide the necessary surface for the precipitation of the Ti film. They are equipped with a mounting flange for the titanium sublimation pump, which carries filaments of a Ti alloy and the necessary current feedthroughs. IGP and TSP are delivered fully mounted on demand. The TSP can be installed separately with your vacuum system as well.

#### Titanium sublimation pump

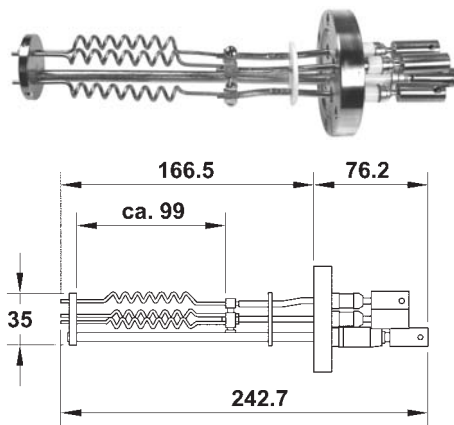

##### Technical data

■ Mounting flange	DN40CF-F
■ Filament material	85 % Ti, 15 % Mo
■ Filament length, total	117 mm
■ Filament length, coiled	60 mm
■ Filament weight	3.1 - 3.5 g
■ Filament lifetime	approx. 20 h, depending on conditions
■ Maximal current	50 A at 8 V DC
■ Number of filaments	3
■ Total weight	1 kg

Order code	Description
360043	titanium sublimation pump
2141400	filament replacement kit

#### Ambient sputter shield

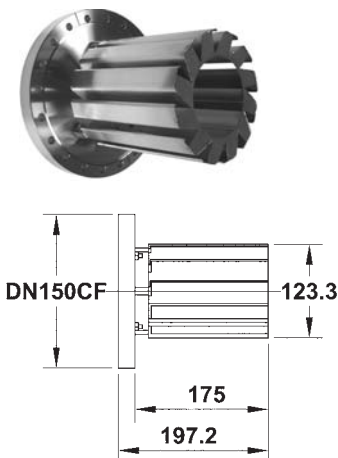

##### Technical data

■ Surface area	1320 cm <sup>2</sup>
■ Mounting flange	DN160CF-F
■ TSP flange	DN40CF-F
■ Total weight	6 kg

Order code	Description
360044	ambient sputter shield

## Titanium Sublimation Pumps (TSP)

### LN<sub>2</sub> cryo chroud

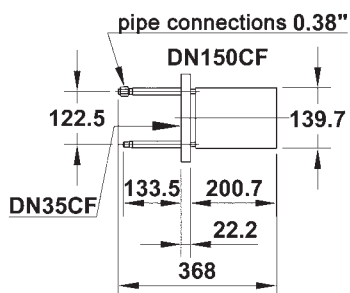

#### Technical data

■ Vaporisation area	880 cm <sup>2</sup>
■ Mounting flange	DN160CF-F
■ TSP flange	DN40CF-F
■ Tank volume	1.15 litre
■ Total weight	8 kg

Order code	Description
360051	LN <sub>2</sub> cooling jacket

Cooling alternatively with water or liquid nitrogen.

## DIGITEL™ MPC - TSP/NEG Power Supply

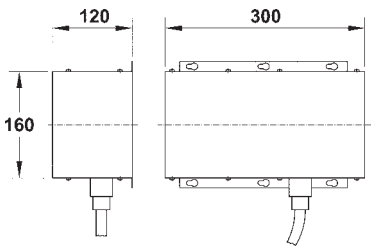

The DIGITEL™ MPC operating device for ion getter pumps (see page 13-6) are designed to control TSP's. All necessary data, such as current, switching-on time, etc. can be entered with the help of the keypad at the front. In order to supply the TSP with power, the power supply for the TSP/NEG remote control has to be connected to the DIGITEL™ MPC. The power supply is in a rugged metal housing and can be installed close to the TSP.

### Technical data

- Dimensions 160 x 120 x 300 mm
- Operating voltage 110 - 240 V, 50/60 Hz
- Output current 0 - 75 A
- Output voltage 12 V DC
- Operating methods continuously, time triggered, set point controlled
- Weight 12.2 kg

Order code	Description
635930	DIGITEL™ MPC - TSP/NEG power supply

## SUBLI-CON51

Independent operating device for titanium sublimation pumps

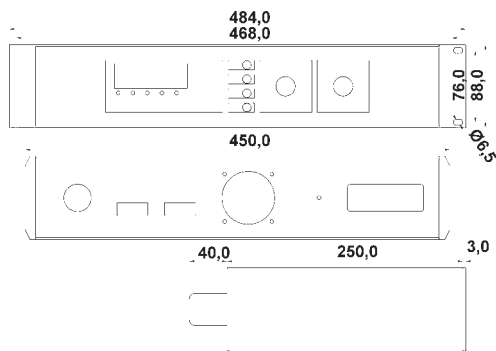

- Controlling of TSPs with up to 4 filaments
- Filaments bakeable
- Manual input function (Start-Stop)
- Internal timing
- Interlock and remote control
- Automatic or manual filament selection
- 19" rack installation, 2 HU

### Technical data

- Sublimation times 1 to 10 min
- Pause time 1 ... 48 h
- Operation manual input with start/stop function  
intern timing with start/stop function  
remote control with start/stop function
- Heat current max. 50 A
- Operating voltage 115/230 V, 50 ... 60 Hz
- Power max. 600 VA
- Dimensions H x B x T: 88 x 450 x 253 mm
- Weight 10.5 kg

Order Code	Description
SUBLI-CON51	power supply for titanium sublimation pumps (TSP)

The Subli-Con51 is delivered incl. 3 m connecting cable (other lengths on request)  
Please specify the cable connection on the pump side:  
Without plug, with ears or individual plug type of your TSP.

### Ion Getter Pumps

#### General Information

##### Development of ion getter pumps

The invention of the ion getter pump, which is also called sputter ion pump (SIP), was a coincidence which happens quite frequently with technical inventions. In the 1930s F. M. Penning carried out some research with cold cathode ionisation gauges. He published his results explaining the connection between vacuum creation and molecular ionisation in these gauges in 1937. At the end of the 1940's, the term Penning Cell was introduced in connection with vacuum measurement, while the pumping action was predominantly seen as a side effect. Nonetheless the potential of this side effect was realised and shortly after the first single-cell ion pump was patented in the U.S.A. The pumping capacity was less than 1 l/s. Numerous technical advancements lead to multi-cellular pumping elements. These pumping elements - installed in a coming housing - form the nowadays most famous type of the IGP.

##### Vacuum creation with ion getter pumps

The IGP was used in almost every single vacuum application in high vacuum pressure ranges of up to  $<10^{-6}$  mbar before the promotion of turbo molecular pumps. Nowadays IGP with larger pumping speeds are mostly used in pressure ranges  $<10^{-9}$  mbar. For those applications, ion pumps remain the cleanest and most efficient method of achieving ultra high vacuum. IGP capture and hold gases by converting them into solid compounds and binding them in the pump. Because of that, ion pumps maintain the vacuum even while not in operation. Ion pumps do not have any moving parts. Therefore they are ideal for sealed systems that require reliable and long-term operation. Furthermore IGP operate completely free of vibrations and agitation at very low power consumption. Maintenance is minimal throughout the whole lifetime.

##### Typical applications

The still growing list of IGP applications is already long. IGP are an integral part of such scientific apparatus as in particle accelerators, mass spectrometers and the surface analysis. Furthermore, IGP are used in the fabrication of vacuum tubes, the development and production of semiconductor devices, space simulations and many other areas. In particular, the applications as electron microprobes and particle beam devices should be mentioned here. Although relatively high pressures are involved, the IGP is essential because of its complete vibration resistance.

#### Characteristics of Ion Getter Pumps

##### Pumping speed

As with any vacuum pump, pumping speed is the major factor in determining the lowest (or "ultimate") pressure of a system and the time required to achieve this pressure. The speed at which a particular gas is pumped varies depending mainly on the chemical properties of the gas. Chemical reactivity, ionisation potential, mass and size of the species affect the rate of its removal from the system. In sputter-ion pump science, the elements are labelled chemically active or noble. Reactive gas ions have a tendency to chemically react with cathode materials and form new solid compounds. For example, an ionised oxygen molecule will borrow an electron from, and readily react with, a titanium cathode atom. The newly formed titanium oxide molecule becomes a neutral solid and is not reintroduced as a gas. The noble gases have filled electron shells and are thereby not reactive. Because of that, they are not chemically bound. Noble gases can only be bound by physisorption (physical bonding) on the surface or the implantation in the surrounding walls of the pump. In addition to the gas character, the pumping speed of an IGP also depends on the construction of the pumping elements. In the table 1 you can find examples for the percentual pumping speed of different pumping elements for individual gases related to the pumping speed of air.

##### Saturation effects

Prior to operating an IGP for the first time, the cathodes are unsaturated and the cathode material has not been combined with gases. A new ion pump actually pumps up to twice the steady state pumping speed. After several hours of operation (at typical starting pressures), with a constant gas load, the pump achieves a steady state wherein the amount of gas being pumped is equal to the amount of gas being released from the pump walls. If the primary gas component is altered, this effect will again be noticed until the pump saturates with the new species. For this reason ISO/DIS 3556-1 (an unpublished standard for testing SIPs) requires all reported pumping speeds to be obtained from a saturated pump.

##### Stability

Stability, or pressure stability, is the ability to maintain a constant pressure given a constant gas load. Different cathode materials provide varying levels of stability and pumping speed. Titanium cathodes remain stable when pumping reactive gases. Unfortunately, while pumping noble gases (argon being the most typical) with titanium cathodes, instabilities result. Noble gases do not react with titanium and are simply buried in titanium cathodes. This increasingly happens in the centres of the cells. Upon added sputtering of the cathode, there is the potential for these gases to be released back in the vacuum environment. Alternatively, cathodes made of tantalum are used. Although they don't retain noble gases, they do aid in stable pumping. Ions contacting the tantalum cathode are reflected back into the ion pump as high energy neutrals. These molecules usually are repelled with enough energy to bury themselves in other areas of the pumping element (e.g. within the anode structure). At that location no or only very little sputtering occurs and therefore once implanted atoms are not released again and remain in the solid.

##### Starting pressure

All ion pumps require rough pumping of the vacuum system prior to operation. The range to start diode ion pumps is  $<10^{-4}$  mbar or lower. At this pressure ionisation is confined to within the anode structure of the pumping element. When ionisation occurs outside of the pumping element, the power supply is not able to maintain the electric field. The power supply sees a virtual "short" due to the electric conduction of charged particles. Ion pump controllers monitor this condition and limit the power output to protect the supply and pump from damage.

## Ion Getter Pumps

### Lifetime

Ideally the operating life of an ion pump is determined by the amount of cathode material. However, electrical leakage between anode and cathode caused by sputtered-metal films typically limits the life of an ion pump.

### Bakeability

Increasing the temperature (baking), an ion pump allows lower pressures to be reached faster due to increased outgassing from internal pump surfaces. Ion pumps can withstand bake temperatures in excess of 450 °C. Magnets can withstand temperatures up to 300 °C, cables only up to 250 °C. Both must be removed for applications requiring higher temperatures.

### Magnetic field

The magnetic field directly affects the pumping speed. Above 85 °C, the pumping speed of an ion pump declines with temperature. Ion pumps have difficulty maintaining operation above 250 °C because of magnetic field loss. The ceramic magnets used exhibit reversible field loss of 0.2 % per degree Celsius and an irreversible field loss of 7 % at 350 °C. This loss is non-cumulative (subsequent bakeouts to 350 °C do not cause an additional irreversible loss).

## Pumping mechanism of diode ion pumps

A diode ion pump consists of one or more pumping element/s and the corresponding external permanent magnets and the pump housing. The pumping elements are the parts of the pump doing the actual pumping work. Every pumping element consists of 2 cathode plates and an anode element, or shorter anode. The anode in turn consists of numerous cylindrically shaped short metal tubes, which are welded together like honeycombs. Every single tube forms the centre of a Penning cell. The more cells an anode has, the higher is the pumping speed of the pumping element, which is built of such. The anode is allocated between the two cathode plates, which are separated by a gap from the anode. This gap is large enough that the inflow of gas is possible. Anode and cathode are connected tightly and are electrically isolated by ceramic isolators. They form the pumping element. One or more pumping element/s are installed in the pump housing, which is a small vacuum chamber that has pockets to capture these pumping elements. Completing the setup, the permanent magnets are attached to these pockets from the outside. For the functioning of an IGP mainly three processes are essential, which are explained below.

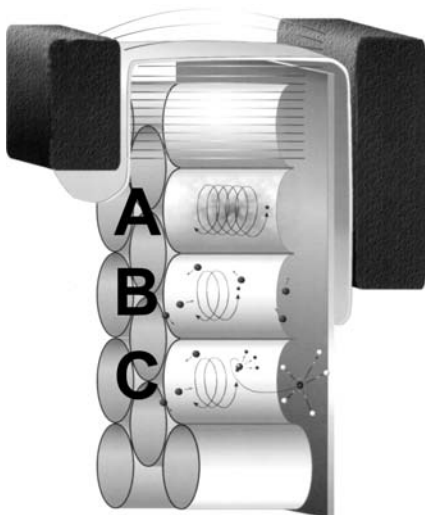

### 1) Electron cloud development (figure, section A)

Once the ion pump has been rough pumped to appropriate starting pressures, a positive charge is applied and a cloud of electrons, ions and possibly photons forms within the anode structure. The voltage level applied to the anode rings directly affects the density of charged particles as well as their velocity. Because of the magnetic field induced by permanent magnets, the electrons are forced on spiral orbits. The density of the cloud is also proportional to the pressure of the system. In general the density decreases as the pressure decreases because fewer electrons are freed by molecular ionisation and fewer gas molecules are floating free. Pressure and voltage also affect the diameter of the electron cloud. Anode structures are engineered to achieve the best ionisation rate, conductance and burial rate of gas molecules.

### 2) Gas molecule ionisation (figure, section B)

Neutral gas molecules and atoms in the electron cloud are ionised when colliding with electrons of sufficient energy. The electrons freed during the process become a part of the electron cloud and help ionising other molecules themselves. The higher the applied voltage, the faster are the electrons in the electron cloud and the higher is the ionisation probability. The original gas molecule is left as a positive ion within the positively charged high voltage anode. Under the action of strong electromagnetic forces the ion is accelerated from the anode towards the negatively charged cathode reaching a kinetic energy that is approximately equivalent to the applied high voltage.

### 3) Ion impact (figure, section C)

Positively charged ionised gas molecules impact the cathode with a high amount of energy. Upon the impact, several things occur simultaneously. The ionised gas molecule may immediately react with the cathode, combining chemically with a cathode atom. This "sputtering" action distributes cathode material throughout the ion pump element, which enables fresh cathode material to be available for chemical combination with reactive gases independent of the molecules charge. If an ionised gas molecule does not readily react with the cathode material, it is simply driven into the cathode material or reflected back into the pump at some angle. The ionised gas molecule becomes neutrally charged at the moment of impact. There is a chance that a reflected high-energy neutral molecule can travel unhindered toward another pump surface and bury itself within the lattice. The molecule mechanism for removal from the pressure system is either chemical or physical and depends upon the gas species as well as the cathode material. These factors also play a role in whether newly formed molecules settle onto pump walls, implant into the cathode, or reflect as high-energy neutrals at extremely high velocities.

## Ion Getter Pumps

### Pump Element Styles

Over the years, various types of pump elements were developed. The most important ones are described below:

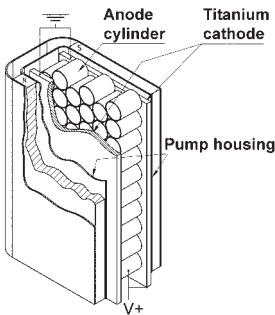

#### Conventional diode elements

Conventional elements provide the highest air and reactive gas pumping speeds. They consist of a titanium cathode on each side of the anode structure. The pumping speed for inert gases is typically an order of magnitude lower than for active gases. These pump elements are especially useful for the usage in lower UHV and XUHV or in closed vacuum systems, which are vented rarely. Because of the lower pumping speed of noble gases, conventional ion pumps are best when inert gases will not be intentionally introduced.

#### Differential (noble gas stable) diode elements

Differential elements operate similarly to conventional elements, however a tantalum cathode is substituted for one titanium cathode plate. This substantially boosts the noble gas stability. Differential elements can effectively pump against a 100 % air or argon leak (1 % Ar by volume) and remain stable. They are suitable for applications in UHV, during which a high pumping speed for reactive and noble gases is essential at the same time.

Gas type	Noble gas stable diode TiTan DI	Conventional diode TiTan CV
H <sub>2</sub>	160	220
CO <sub>2</sub>	100	100
N <sub>2</sub>	85	85
O <sub>2</sub>	70	70
H <sub>2</sub> O	100	100
Ar	20	2

Table: Pumping speed in comparison with air (% of nominal value)

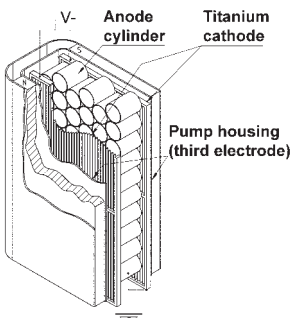

#### Triode pump elements

Triode style elements operate pump elements where the cathodes are either metal strips or flat plates of titanium. Triode means, that there are three electrodes, anode, cathode and the barrier of the pump housing. Anode and pump housing are positively charged and the cathode is negatively charged. Opposite to diode ion pumps not the anodes, but the cathodes are supplied with high voltage. The applied high voltage has negative polarity. In service, the ion impact on the edges and surfaces of the titanium strips and are sputter them. Furthermore, the particles are neutralised and are mostly reflected in the direction of the pump housing barrier. Reactive and noble gases are then bonded by the depositing cathode material or are implanted in the walls of the ion pump body. Triode designs typically start operating at higher pressures, but lack pumping speed at UHV and are thus suited for HV applications. Triode elements can not obtain constant and stable UHV pressures.