

CF Micro Flanges DN10

- Space saving in plant construction
- Material: Stainless Steel 1.4404 / 316L
- Further components using micro flanges available:
 - Rotary motion feedthroughs
 - Linear shift mechanism
 - Electrical and liquid feedthroughs
- Zero length flange adapter DN16 to DN10 and DN40 to DN10 available

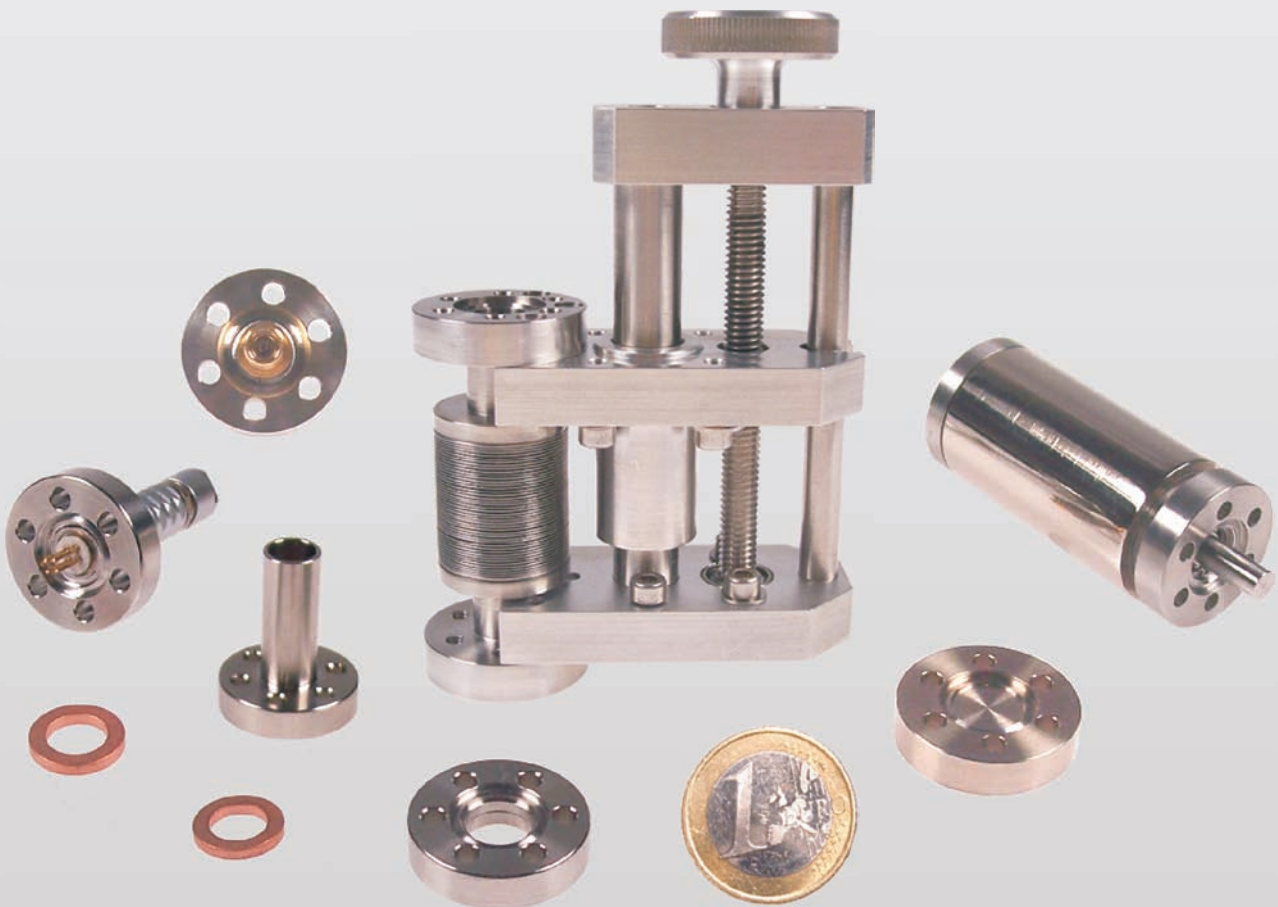

Flanges

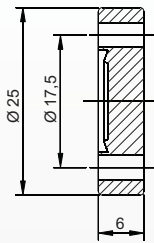

F10-316
CF blank flange Dn10
Stainless steel 316L

F10T-316
CF blank flange DN10,
with tapped bolt holes
Stainless steel 316L

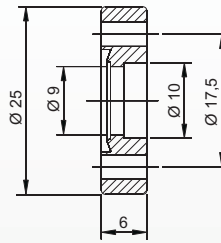

F10B10-316
CF bored flange Dn10
Stainless steel 316L

F10B10T-316
CF bored flange DN10,
with tapped bolt holes
Stainless steel 316L

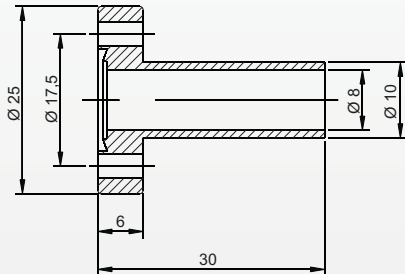

TU10-30-10-316
CF tubulation Dn10
Stainless steel 316L

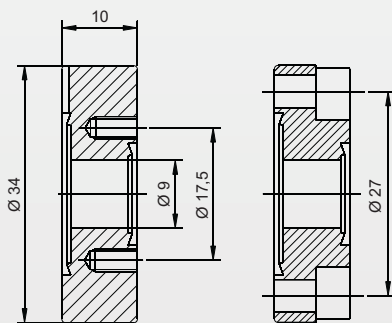

ZL016010-316
CF zero length adapter
DN16 to DN10
Stainless steel 316L

■ useable with
6 x M4 socket screws and
6 x M3 bolt and washer sets

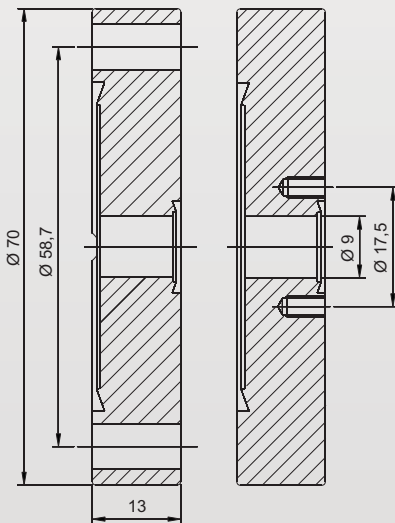

ZL040010-304
CF zero length adapter
DN40 to DN10

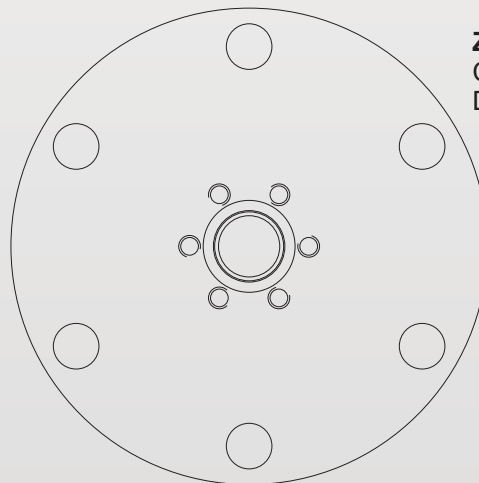

Seals

CU10
CF copper gasket DN10, OFHC-copper
packing unit 10 pieces

VGF10
CF gasket, Dn10, FKM,
packing unit 1 piece

Connecting elements

NBW316 Bolt sets, ISO 4017, M3, length 16 mm, A2,
consisting of nut, bolt and washer, packing unit 25 pieces

NBW320 Bolt sets, ISO 4017, M3, length 20 mm, A2,
consisting nut, bolt and washer, packing unit 25 pieces